

RAMMER RPV03S STATIC PULVERIZER



SPEED VALVE
Shorter working cycles
increase productivity

FIELD REPLACEABLE WEAR PARTS
Minimise downtime as there is no need for welding/rebuilding

HEAT TREATED PINS AND BUSHINGS
Hardened parts are more wear resistant, extending their working life and lowering owning and operating costs

GRATED JAW DESIGN
The fixed jaw allows crushed material to pass through increasing productivity

MANUFACTURED OF HB400 STEEL
Highly resistant material to work on concrete

BOLT ON CUTTING BLADES
Field replaceable and adjustable cutter blades minimize downtime and significantly increase the working life of wear parts

RPV STATIC PULVERIZERS

The Rammer RPV Static Pulverizer range is ideally suited to a wide range of secondary demolition and recycling duties. The RPV range of models are designed for fast and effective material separation, a key aspect of the recycling process.

Rammer[®]

RPV03S

SPECIFICATIONS

Working weight, kg	150
Operating pressure, bar	200-250
Oil flow, l/min	30-60
Blade length, mm	80
Carrier weight, range, ton	1.5-4

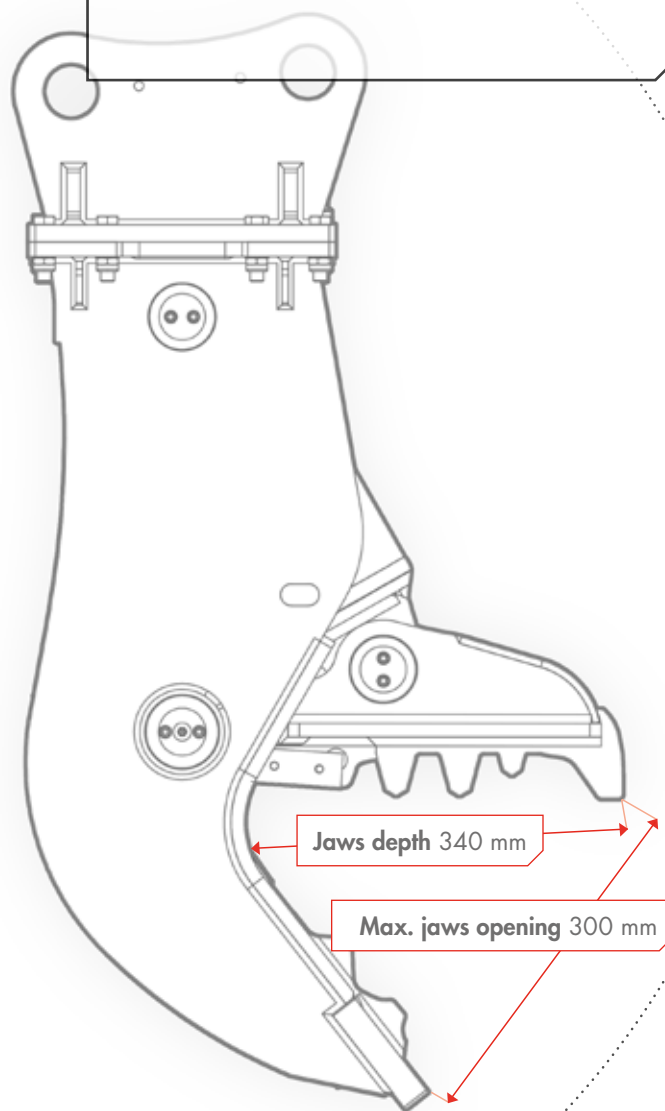
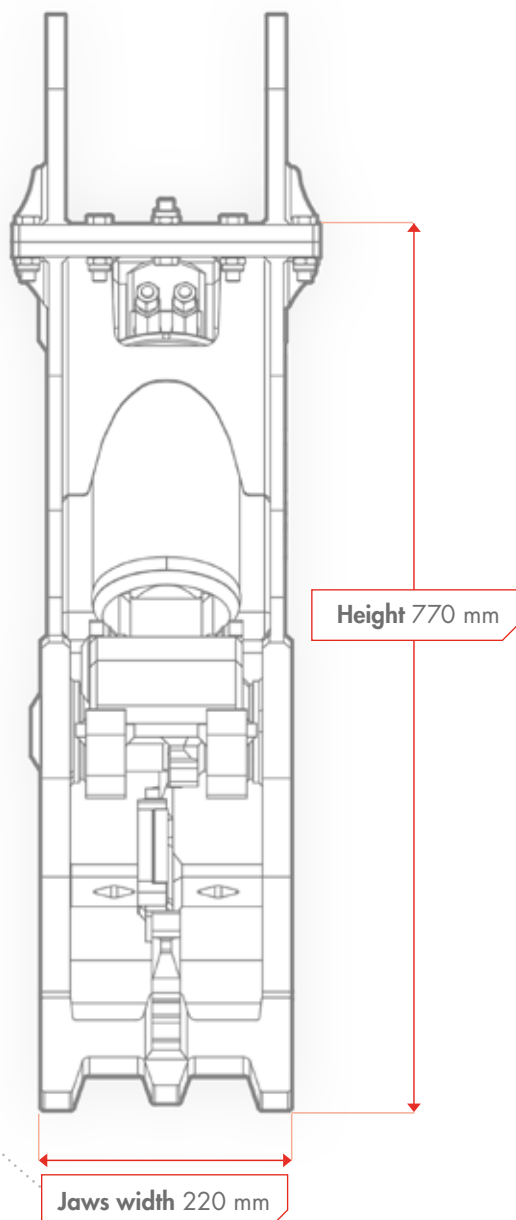

Sandvik Mining and Construction Oy
Taivalkatu 8, P.O.Box 165
FI-15101 Lahti, Finland
Phone Int. +358 205 44 151
www.rammer.com

**Ram
mer**[®]